

Mini Translation Motorized Stages - 5 Phase Stepping Motor | MTMS Stage size □40/□60mm



Application Systems

Machine Vision

Manual Positions

Motion Control Products

Optical & Mirror Holder

FA Parts

Measurement & Control

FA Electrical Parts

Tool & Measure

Cleanroom & AntiStatic

Index

Piezo Stage

Precision Linear MS

High Speed MS

Motorized Goniometer

Motorized Rotation

Multiaxis Motorized

Industrial Robot

Controller & Driver & Cable

Custom-Built MS

Low price motorized stages fitted with integrated extended contact bearings and precision ground screws.



- Cost-effective motorized stages achieved by integrated structure in which guides are directly processed on the main body.

Guide

- ▶ If you desire to mount this product on an XY or Z axis stage, or to change the motor, contact our International Sales Division. Or, use the motorized stage system question sheet. [Reference](#) I085

Specifications			MTMS40-15X	MTMS60-20X	
Part Number					
Mechanical Specifications	Travel [mm]		15	20	
	Table Size [mm]		40×40	60×60	
	Feed Screw [mm]		Precision ground screw φ5mm, 0.5mm lead		
	Positioning Slide		Extended Contact Ball Guide		
	Stage Material		Steel		
	Finish		Super black chrome		
	Weight [kg]		0.35	0.6	
Accuracy Specifications	Resolution	(Full) [μm/pulse]	1	1	
		(Half) [μm/pulse]	0.5	0.5	
	MAX Speed [mm/sec]		5	5	
	Positioning Accuracy [μm]		20	20	
	Positional Repeatability [μm]		10	10	
	Load Capacity [N]		29.4 (3.0kgf)	39.2 (4.0kgf)	
	Moment Stiffness	Pitch [°/N·cm]		0.4	0.2
		Yaw [°/N·cm]		0.4	0.2
		Roll [°/N·cm]		0.4	0.2
	Lost Motion [μm]		10	10	
	Backlash [μm]		10	10	
	Parallelism [μm]		50	50	
	Running Parallelism [μm]		10	10	
Pitch [°] / Yaw [°]		20/20	20/20		
Sensor	Sensor Part Number		Micro photo sensor: GP1S092HCPI (Sharp Corporation)	Micro photo sensor: PM-L24 (SUNX Co., Ltd.)	
	Limit Sensor		Equipped (NORMAL CLOSE)		
	Origin Sensor		None		
	Proximity Origin Sensor		None		

Motor / Sensor Specifications		
Motor	Type	5-phase stepping motor 0.35A/phase (Oriental Motor Co., Ltd.)
	Motor Part Number	PK513PB-C9 (□20mm)
	Step Angle	0.72°
Sensor	Power Voltage	DC5 – 24V ±10%
	Current Consumption	40mA or lower (20mA per sensor) 30mA or lower (15mA or lower per sensor)
	Control Output	NPN open collector output 50mA NPN open collector output DC30V or lower, 50mA
	Output Logic	When shaded: Output transistor OFF (no conduction)

Compatible Driver / Controller		
Control System	Compatible Driver	SD-5MA, SD-55MA, SD-514MSC
	Compatible Controller	ASC-PS, ASC-01, ASC-102, ASC-02, ASC-702, ASCG-101, ASC-302GS, ASC-304GS, ESC-M/ESC-S

Mini Translation Motorized Stages - 5 Phase Stepping Motor

MTMS Stage size □40/□60mm



Outline Drawing

MTMS40-15X Hexagonal socket head cap screw M3x8...4 screws

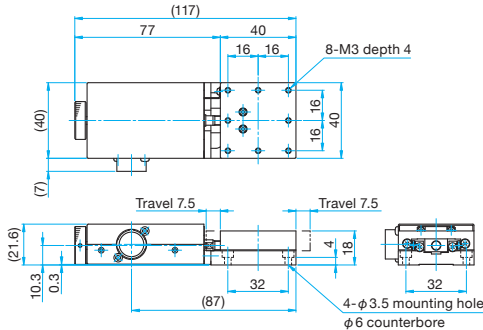

MTMS60-20X Hexagonal socket head cap screw M4x6...4 screws

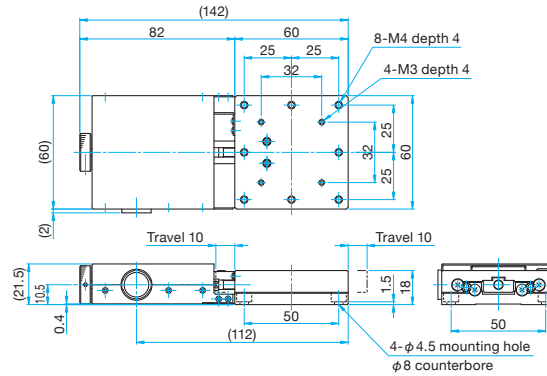

Connection Diagram (MTMS40-15X)

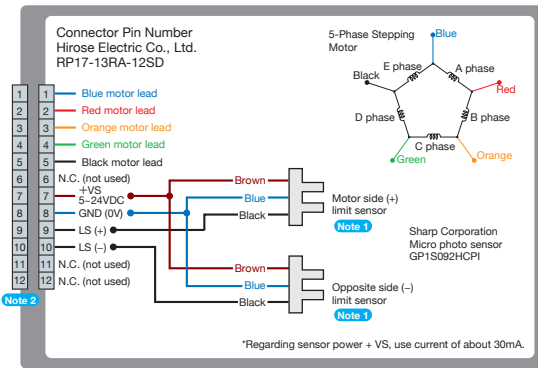

Compatible Controllers / Drivers and Cables

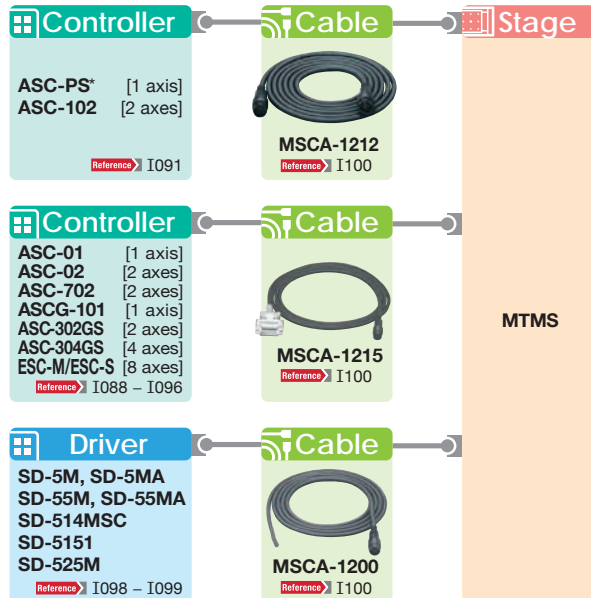

* PASC-PS will be discontinued in September 2012, and will be replaced by ASC-01.

Connection Diagram (MTMS60-20X)

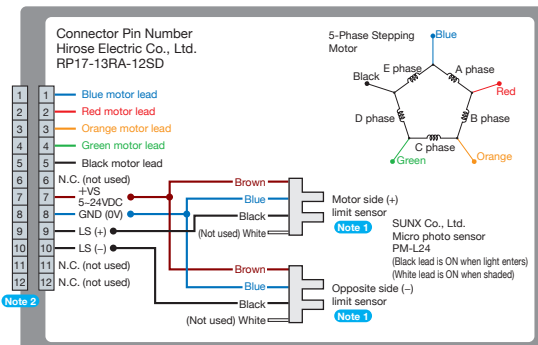

Note 1 The motor side limit sensor is the + direction limit sensor. Motorized stages are not fitted with origin and proximity origin sensors. Limit sensors are used as origin detection sensors.

Note 2 Compatible cable connector: Hirose Electric Co., Ltd. RP17-13PA-12PC/RP17-PC-122

Application Systems

Machine Vision

Manual Positions

Motion Control Products

Optical & Mirror Holder

F A Parts

Measurement & Control

FA Electrical Parts

Tool & Measure

Cleanroom & AntiStatic

Index

Piezo Stage

Precision Linear MS

High Speed MS

Motorized Goniometer

Motorized Rotation

Multiaxis Motorized

Industrial Robot

Controller & Driver & Cable

Custom-Built MS