

NEW Vacuum Compatible Motorized Stages

VCMS

- Application Systems
- Machine Vision
- Manual Positions
- Motion Control Products**
- Optical & Mirror Holder
- FA Parts
- Measurement & Control
- FA Electrical Parts
- Tool & Measure
- Cleanroom & AntiStatic
- Index

Motorized stages fitted with a limit sensor compatible with vacuum environments.

- Linear system has a long travel between 35 – 200mm, and is as compact as the conventional SGSP series.
- Rotation stages are low-profile, but offer high load capacity due to □42mm motor.



Guide

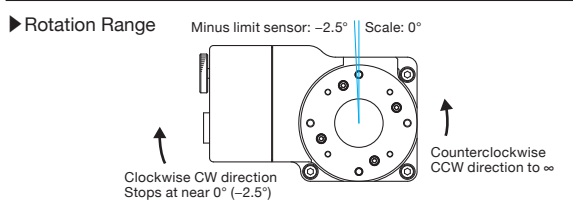

- Homing of rotation motorized stages is performed using the CW limit sensor as the origin sensor.
- Origin detection is adjusted so that the stage stops at 0 degree when homing is performed in the MINI system at half step.

Specifications

| Part Number | | NEW VCMS-120YAW | |
|---------------------------|--------------------------|--|---------|
| Mechanical Specifications | Travel or Rotation Range | Counterclockwise CCW direction to ∞, Clockwise CW direction stops at near 0 degree (-2.5°) | |
| | Table Size [mm] | φ120 | |
| | Feed Screw [mm] | Worm and worm wheel | |
| | Positioning Slide | Crossed roller | |
| | Stage Material | Aluminum / Stainless steel | |
| | Finish | None | |
| | Weight [kg] | 1.7 | |
| Accuracy Specifications | Resolution | (Full) | 0.005° |
| | | (Half) | 0.0025° |
| | MAX Speed | 20°/sec | |
| | Positional Repeatability | 0.02° | |
| | Load Capacity [N] | 98.0 (10.0kgf) | |
| Lost Motion | 0.05° | | |
| Sensor | Sensor Part Number | GN-STM35A-1 (Metrol Co., Ltd.) | |
| | Limit Sensor | Vacuum touch sensor (NORMAL OPEN) | |
| | Origin Sensor | None | |
| | Proximity Origin Sensor | None | |

Motor / Sensor Specifications

| | | |
|--------|---------------------|---|
| Motor | Type | Vacuum compatible 5-phase stepping motor 0.75A/phase (Oriental Motor Co., Ltd.) |
| | Motor Part Number | PK543V-NB (□42mm) |
| | Step Angle | 0.72° |
| Sensor | Power Voltage | DC5 – 24V |
| | Current Consumption | 10mA (Max 20mA) |
| | Control Output | Mechanical |
| | Output Logic | NORMAL OPEN |

Compatible Driver / Controller

| | | |
|----------------|-----------------------|---|
| Control System | Compatible Driver | SD-5M, SD-55M, SD-514MSC, SD-5151, SD-525M |
| | Compatible Controller | ASC-PS, ASC-01, ASC-102, ASC-02, ASC-702, ASCG-101, ASC-302GS, ASC-304GS, ESC-M/ESC-S |

- Piezo Stage
- Precision Linear MS
- High Speed MS
- Motorized Goniometer
- Motorized Rotation**
- Multiaxis Motorized
- Industrial Robot
- Controller & Driver & Cable
- Custom-Built MS

NEW Vacuum Compatible Motorized Stages

VCMS



Outline Drawing

VCMS-120YAW

Hexagon socket head cap screw M6x10...3 screws

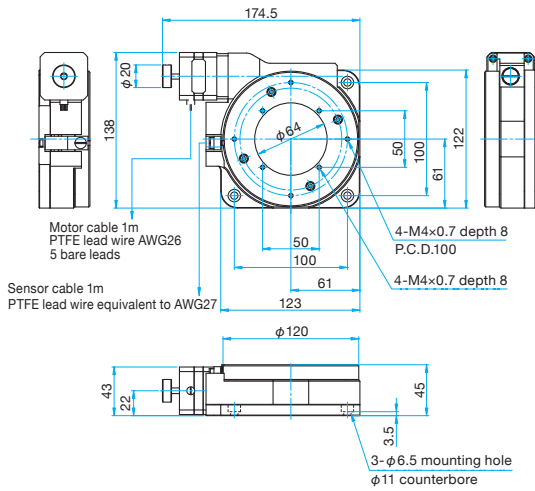

Connection Diagram

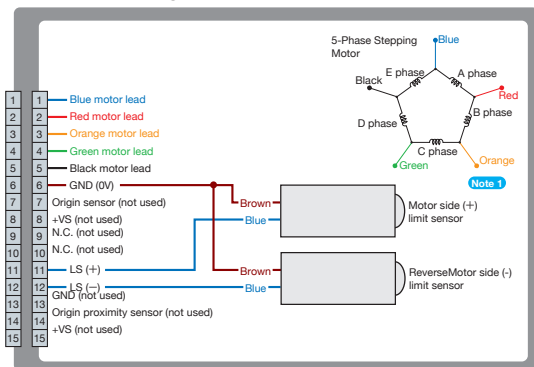

Limit Sensor (high vacuum compatible switch)

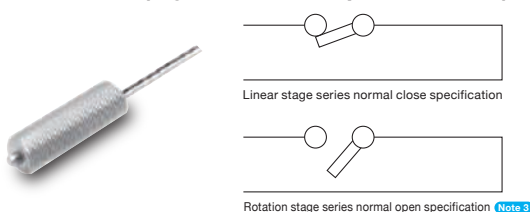

Note 3 Set the controller of vacuum compatible motorized rotation stages to normal open.

Compatible Controllers / Drivers and Cables

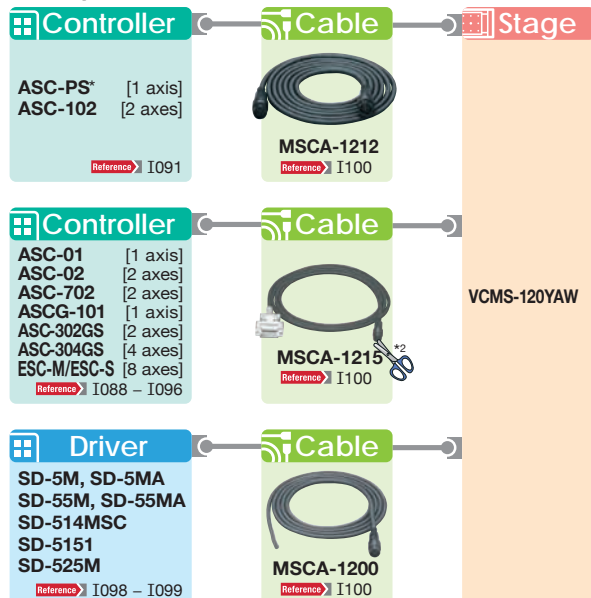

* PASC-PS will be discontinued in September 2012, and will be replaced by ASC-01.
 *2 Make the cable into bare wire specification after purchase.

Application Systems

Machine Vision

Manual Positions

Motion Control Products

Optical & Mirror Holder

F A Parts

Measurement & Control

FA Electrical Parts

Tool & Measure

Cleanroom & AntiStatic

Index

Piezo Stage

Precision Linear MS

High Speed MS

Motorized Goniometer

Motorized Rotation

Multiaxis Motorized

Industrial Robot

Controller & Driver & Cable

Custom-Built MS