

产品技术规格书 (Product Technical Specification)

No.	名称 (Name)	规格 (Specification)	No.	名称 (Name)	规格 (Specification)	
1	型号 (Model)	ZMHL-0311	14	视场角 F.O.V (DxVxH)	23"	
2	物料代码 (Material Code)	0202-2105121611			D	11.30-17.37
3	靶面格式 (Image Format)	23"			H	9.05-13.94
4	分辨率 (Resolution)	3MP			V	6.79-10.47
5	放大倍率 (Magnification)	0.3X~1.1X	15	接口 (Mount)	C	
6	后截距 (Back Focus)	12.78mm	16	适用物距 (Suitable Distance)	0.083-0.103m	
7	F值 (FNo.)	7.6	17	最佳物距 (Optimum Working Distance)	0.093m	
8	光圈 (Iris Type)	Manual	18	镀膜 (Coating)	400nm-900nm	
9	畸变 (Distortion)	-0.1%~1.1%	19	外形尺寸 (Dimension)	φ38×88.58	
10	通光口径 (Lens Effective Diameter)	前面 (Front)	φ22.95mm	20	重量 (Weight)	g
		后面 (Back)	φ8.86mm	21	工作温度 (Operating Temperature)	-20°C~+65°C
11	相对照度 (Relative Illuminate)	89	22	镜头组成 (Lens Construction)	16-10	
12	光学总长 (TTL)	96mm	23	最大主光线入射角 (CRA)	7.76°	
13	设计波长 (Design Wavelength)	400~700nm	24	滤镜尺寸 (Filter Thread)	M34×0.5	

Size:

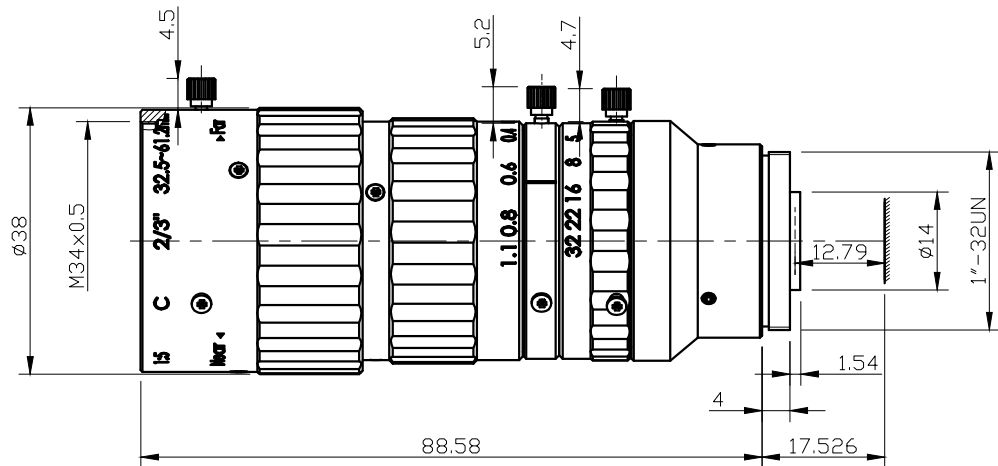

Unit:mm

Draw	Check	Recheck	Approval	www.hours-web.com