

α axis Goniometers α axis Goniometers

MGT11-15 Stage size 15mm
MGT11-25 Stage size 25mm



Goniometers fitted with dovetail slide and worm gear, suitable for orientation adjustment (angle adjustment or correction).

- The goniometer with stage size 15mm (MGT11-15-10) is unique to Sigma-Koki.

Stage 15mm

Rotation Center Height (W.D) **10 mm**
Angle Range **±20°**
Stage Thickness **10 mm**
Load Capacity **9.8N (1.0kgf)**

Stage 25mm

Rotation Center Height (W.D) **18 mm** **30 mm** **40 mm**
Angle Range **±10°** **±15°** **±20°**
Stage Thickness **10 mm** **12 mm**
Load Capacity **19.6N (2.0kgf)**



Guide

- ▶ To operate the MGT11-15-10, fit a hex wrench to a hexagonal socket.

Attention

- ▶ The MGT11-15-10 is not fitted with scale or clamping mechanism.

Application Systems

Machine Vision

Manual Positions

Motion Control Products

Optical & Mirror Holder

F A Parts

Measurement & Control

FA Electrical Parts

Tool & Measure

Cleanroom & AntiStatic

Index

X Axis

XY Axis

Z Axis

XZ Axis

XYZ Axis

Rotation

Goniometers/Tilt

Multiaxis

Linear Guide

15mm

25mm

40mm

50mm

60mm

70mm

80mm

100mm

120mm

Others

SPEC UP

Specifications		MGT11-15-10	MGT11-25-18	MGT11-25-30	MGT11-25-40
Part Number		MGT11-15-10	MGT11-25-18	MGT11-25-30	MGT11-25-40
Opposite Model		—	MGT11-25-18R	MGT11-25-30R	MGT11-25-40R
Table Size [mm]		15×15	25×25	25×25	25×25
Rotation Center Height [mm]		10±0.1	18±0.1	30±0.1	40±0.1
Angle Range [°]		±20	±20	±15	±10
Vernier Readable Resolution		—	12'	12'	12'
Travel per Knob Rotation [°]		about 5	about 3.1	about 2.17	about 1.67
Rotation Center Displacement [mm]		φ0.1 or less	φ0.1 or less	φ0.1 or less	φ0.1 or less
Positioning Slide		Dovetail slide method	Dovetail slide method	Dovetail slide method	Dovetail slide method
Primary Material		Brass	Brass	Brass	Brass
Finish		Super black chrome	Super black chrome	Super black chrome	Super black chrome
Load Capacity [N]		9.8 (1.0kgf)	19.6 (2.0kgf)	19.6 (2.0kgf)	19.6 (2.0kgf)
Max. Moment Capacity	Pitch [N·m]	0.03	0.35	0.35	0.35
	Roll [N·m]	0.05	0.4	0.4	0.4
Moment Stiffness	Roll ["/N·cm]	—	1.0	1.0	1.0
Parallelism [μm]		50	50	50	50
Weight [kg]		0.02	0.07	0.06	0.06

Catalog Code W7096

Catalog Code W7097



Outline Drawing

MGT11-15-10 Pan head screw M2x5...2 screws 2.5mm

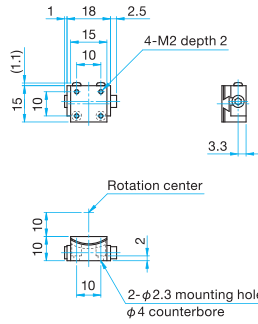

MGT11-25-18 Pan head screw M2x4...4 screws 2.5mm

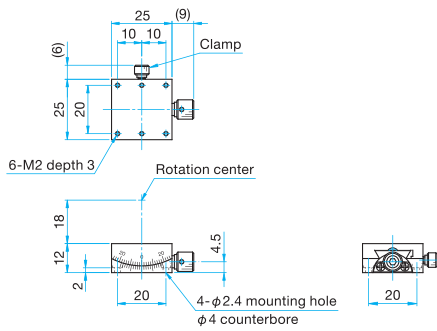

MGT11-25-18R Pan head screw M2x4...4 screws 2.5mm

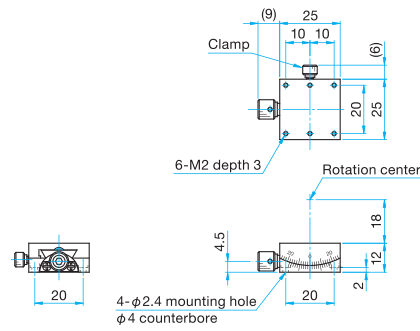

MGT11-25-30 Pan head screw M2x4...4 screws 2.5mm

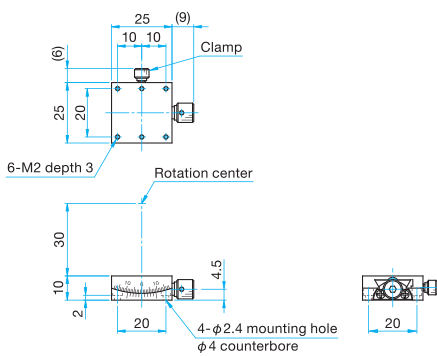

MGT11-25-30R Pan head screw M2x4...4 screws 2.5mm

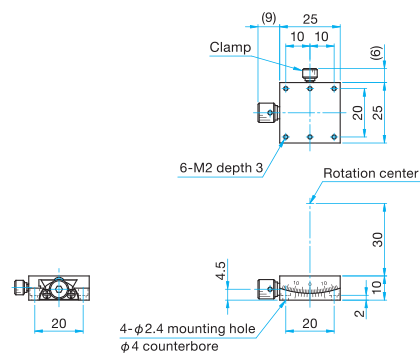

MGT11-25-40 Pan head screw M2x4...4 screws 2.5mm

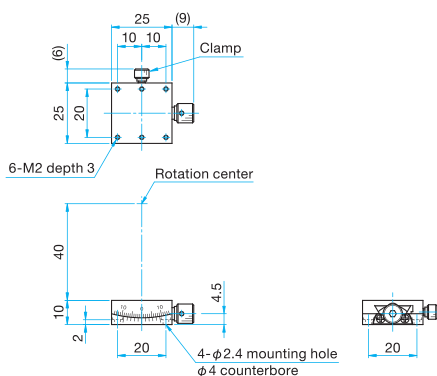

MGT11-25-40R Pan head screw M2x4...4 screws 2.5mm

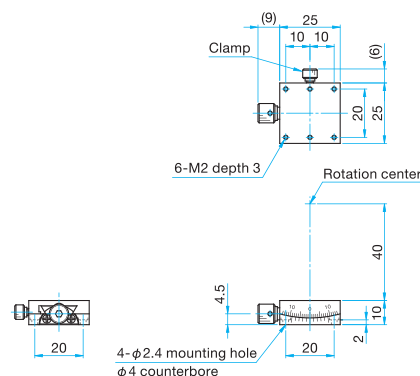

Application Systems

Machine Vision

Manual Positions

Motion Control Products

Optical & Mirror Holder

F A Parts

Measurement & Control

FA Electrical Parts

Tool & Measure

Cleanroom & AntiStatic

Index

X Axis

XY Axis

Z Axis

XZ Axis

XYZ Axis

Rotation

Goniometers /Tilt

Multiaxis

Linear Guide

15mm

25mm

40mm

50mm

60mm

70mm

80mm

100mm

120mm

Others