

## XYZ axis Steel Extended Contact Slide Stages

MLT35-60 Stage size □60mm



Catalog Code W7073

Application Systems

Machine Vision

Manual Positions

Motion Control Products

Optical & Mirror Holder

FA Parts

Measurement & Control

FA Electrical Parts

Tool & Measure

Cleanroom & AntiStatic

Index

X Axis

XY Axis

Z Axis

XZ Axis

XYZ Axis

Rotation

Goniometers /Tilt

Multiaxis

Linear Guide

□15mm

□25mm

□40mm

□50mm

□60mm

□70mm

□80mm

□100mm

□120mm

Others

### Guide

- ▶ The part number suffix FP indicates products with fine-pitch screws instead of standard micrometers.
- ▶ Fine Pitch screws have a screw pitch of 0.25mm and require a hex wrench or the optional hex wrench with knob (NSQ) for adjustment.

Reference ▶ H010



### Outline Drawing

**MLT35-60C** Hexagonal socket head cap screw M4x6...4 screws

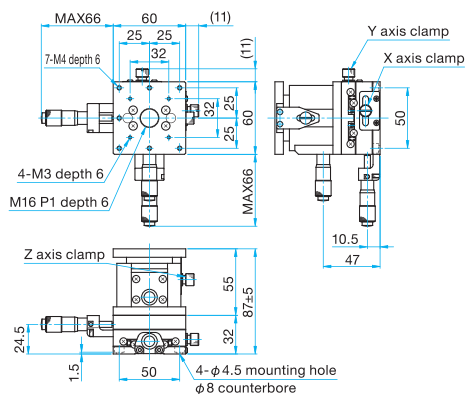

**MLT35-60CFP** Hexagonal socket head cap screw M4x6...4 screws □3mm

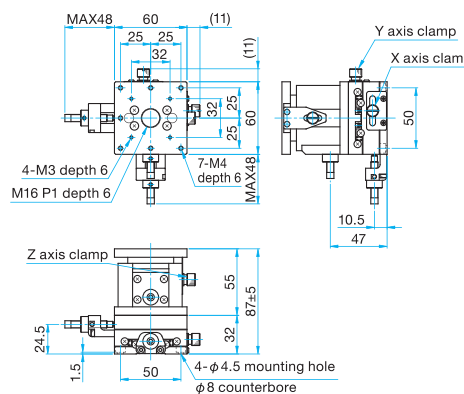

**MLT35-60S** Hexagonal socket head cap screw M4x6...4 screws

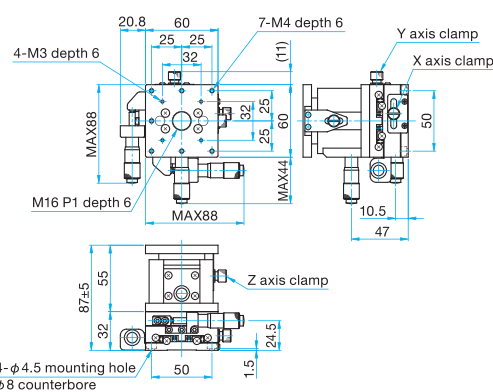

**MLT35-60SFP** Hexagonal socket head cap screw M4x6...4 screws □3mm

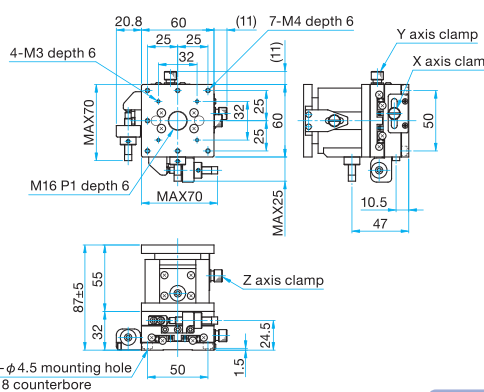

SPEC UP

### Specifications

Table Size [mm]	60×60	
Travel [mm]	XY axis ±6.5, Z axis ±5	
Positioning Slide	Extended contact ball guide	
Primary Material	Steel	
Finish	Super black chrome	
Travel Accuracy	Straightness [μm]	2.5
Max. Moment Capacity	Pitch [N·m]	6.9
	Roll [N·m]	6.9
Moment Stiffness	Pitch [°/N·cm]	0.81
	Roll [°/N·cm]	0.81
Parallelism [μm]	130	

Part Number	TSD-605C	TSD-605CFP	TSD-605S	TSD-605SFP
Micrometer Position	Center	Center	Side	Side
Lead of Actuator [mm/rotation]	0.5	0.25	0.5	0.25
Micrometer Readable Resolution [mm]	0.01	—	0.01	—
Load Capacity [N]	147 (15.0kgf)	39.2 (4.0kgf)	147 (15.0kgf)	39.2 (4.0kgf)
Weight [kg]	1.9	1.9	1.9	1.9

### Configuration

Part Number	MLT35-60C	MLT35-60CFP	MLT35-60S	MLT35-60SFP
Z axis	MLT33-60	MLT33-60FP	MLT33-60	MLT33-60FP
XY axis	MLT32-60C	MLT32-60CFP	MLT32-60S	MLT32-60SFP