

## XYZ axis Steel Extended Contact Slide Stages (Vertical) | MLT35-60 Stage size 60mm

**RoHS** Catalog Code **W7079**

### Guide

- ▶ The part number suffix FP indicates products with fine-pitch screws instead of standard micrometers.
  - ▶ Fine Pitch screws have a screw pitch of 0.25mm and require a hex wrench or the optional hex wrench with knob (NSC) for adjustment.
- Reference ▶ H010



### Outline Drawing

**MLT35-60CL** Hexagonal socket head cap screw M4x6...4 screws

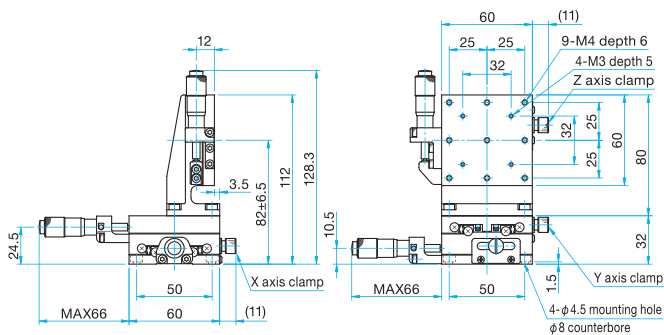

**MLT35-60CLFP** Hexagonal socket head cap screw M4x6...4 screws 3mm

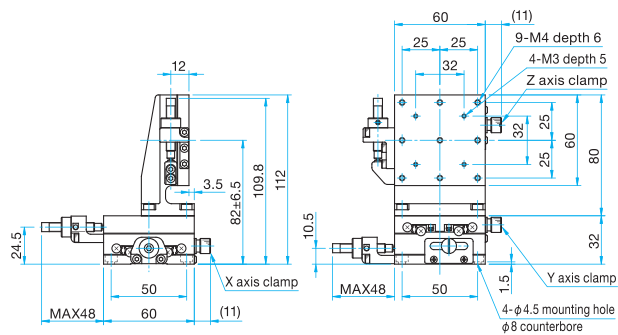

**MLT35-60SL** Hexagonal socket head cap screw M4x6...4 screws

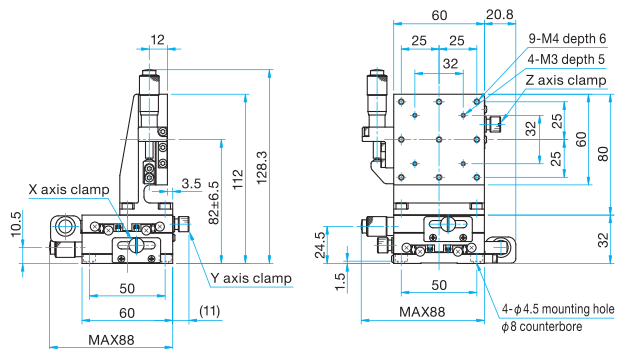

**MLT35-60SLFP** Hexagonal socket head cap screw M4x6...4 screws 3mm

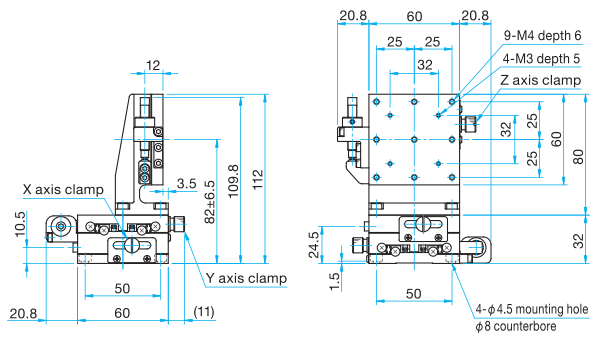

**SPEC UP**

### Specifications

Table Size [mm]	60×60	
Travel [mm]	XY axis ±6.5, Z axis ±6.5	
Positioning Slide	Extended contact ball guide	
Primary Material	Steel	
Finish	Super black chrome	
Load Capacity [N]	49 (5.0kgf)	
Travel Accuracy	Straightness [μm]	1
Max. Moment Capacity	Pitch [N·m]	8.0
	Yaw [N·cm]	8.0
Moment Stiffness	Pitch [°/N·cm]	0.58

Part Number	MLT35-60CL	MLT35-60CLFP	MLT35-60SL	MLT35-60SLFP
Micrometer Position	Center	Center	Side	Side
Lead of Actuator [mm/rotation]	0.5	0.25	0.5	0.25
Micrometer Readable Resolution [mm]	0.01	—	0.01	—
Weight [kg]	1.7	1.7	1.7	1.7

### Configuration

Part Number	MLT35-60CL	MLT35-60CLFP	MLT35-60SL	MLT35-60SLFP
Z axis	MLT33-60L	MLT33-60LFP	MLT33-60L	MLT33-60LFP
XY axis	MLT32-60C	MLT32-60CFP	MLT32-60S	MLT32-60SFP

- Application Systems
- Machine Vision
- Manual Positions
- Motion Control Products
- Optical & Mirror Holder
- FA Parts
- Measurement & Control
- FA Electrical Parts
- Tool & Measure
- Cleanroom & AntiStatic
- Index
- X Axis
- XY Axis
- Z Axis
- XZ Axis
- XYZ Axis
- Rotation
- Goniometers /Tilt
- Multiaxis
- Linear Guide
- 15mm
- 25mm
- 40mm
- 50mm
- 60mm
- 70mm
- 80mm
- 100mm
- 120mm
- Others