

SM1 ($\varnothing 1.035-40$) THREAD

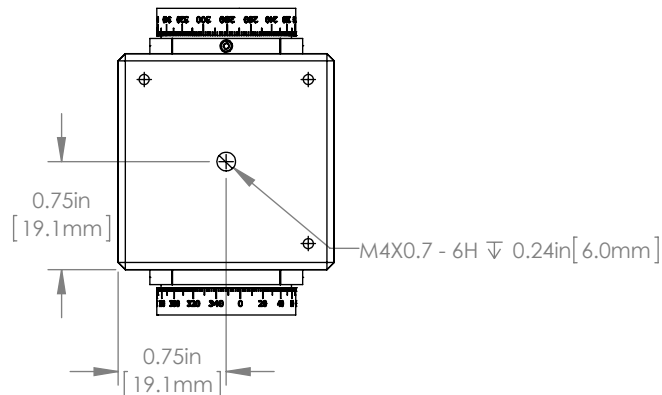
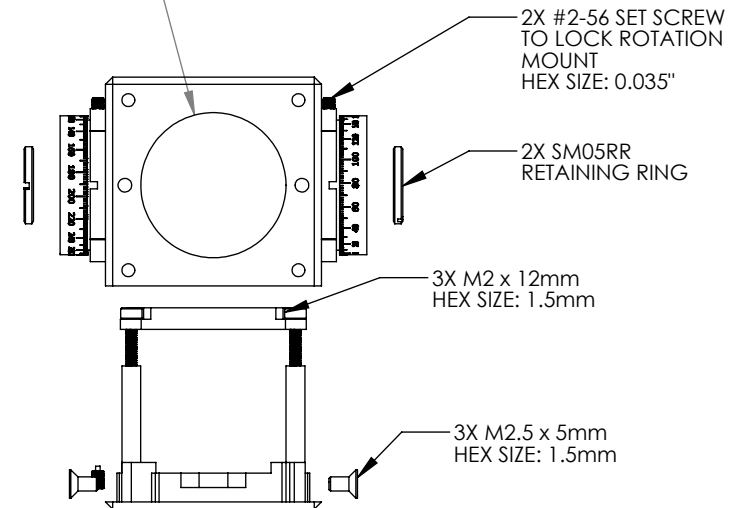

FOR INFORMATION ONLY
NOT FOR MANUFACTURING PURPOSES

DRAWING PROJECTION						HOURS www.hours-web.com	
NAME	DATE	30mm 4-PORT PRISM/MIRROR CAGE MOUNT, 2 ROTATION AT 180°, M4 TAP		MATERIAL		REV	
DRAWN	16/APR/15			N/A		A	
APPROVAL	28/APR/15			ITEM #		APPROX WEIGHT	
VALUES IN PARENTHESIS ARE CALCULATED AND MAY CONTAIN ROUND OFF ERRORS		CCM1-B4ER/M		0.075 kg			