

MAXIMUM CLAMPING HEIGHT

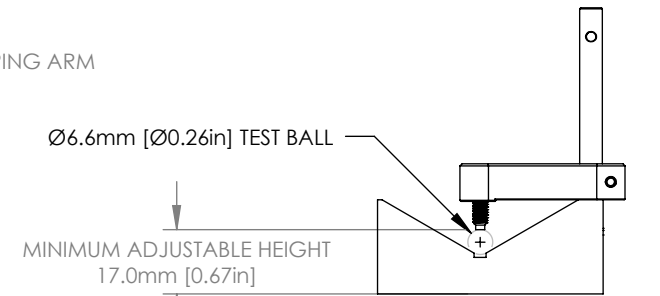

MINIMUM CLAMPING HEIGHT

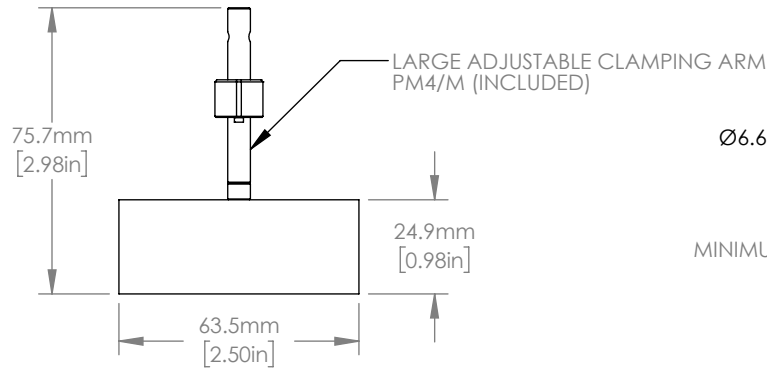
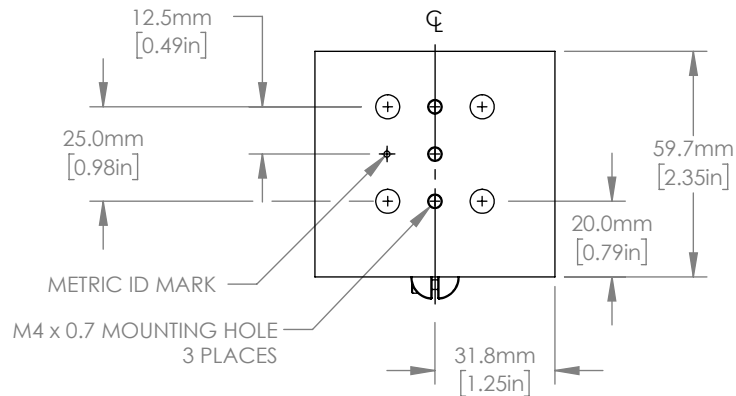

FOR INFORMATION ONLY
NOT FOR MANUFACTURING PURPOSES

DRAWING PROJECTION			 www.hours-web.com	
NAME	DATE	LARGE METRIC V-CLAMP		
DRAWN	22/MAR/16	MATERIAL		REV
APPROVAL	22/MAR/16	N/A		A
VALUES IN PARENTHESIS ARE CALCULATED AND MAY CONTAIN ROUND OFF ERRORS		ITEM #	APPROX WEIGHT	
		VC3C/M	0.09 kg	