

## Z axis Steel Extended Contact Slide Stages (Vertical) | MLT33-60L Stage size □60mm

RoHS

Application Systems

Machine Vision

Manual Positions

Motion Control Products

Optical & Mirror Holder

FA Parts

Measurement & Control

FA Electrical Parts

Tool & Measure

Cleanroom & AntiStatic

Index

X Axis

XY Axis

Z Axis

XZ Axis

XYZ Axis

Rotation

Goniometers /Tilt

Multiaxis

Linear Guide

□15mm

□25mm

□40mm

□50mm

□60mm

□70mm

□80mm

□100mm

□120mm

Others

### Z axis steel extended contact slide stages integrating a stage and Z bracket.

- Hardened Steel linear stages with integrated bearing ways for superior stiffness, accuracy and durability.

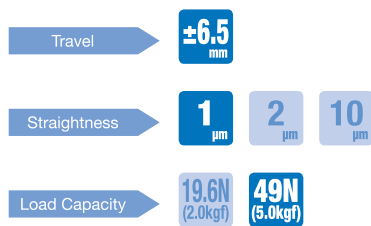

#### Guide

- ▶ The part number suffix FP indicates products with fine-pitch screws instead of standard micrometers.
- ▶ Fine Pitch screws have a screw pitch of 0.25mm and require a hex wrench or the optional hex wrench with knob (NSC) for adjustment.



Reference H010

Specifications			
Table Size [mm]		60×60	
Travel [mm]		±6.5	
Positioning Slide		Extended contact ball guide	
Primary Material		Steel	
Finish		Super black chrome	
Load Capacity [N]		49 (5.0kgf)	
Travel Accuracy	Straightness [μm]	1	
Max. Moment Capacity	Pitch [N·m]	8	
	Roll [N·m]	8	
Moment Stiffness	Pitch [°/N·cm]	0.25	
Running Parallelism [μm]		20	
Angularity [μm]		30	

Part Number	MLT33-60L	MLT33-60LFP	MLT33-60DML	MLT33-60LWP
Opposite Model	MLT33-60RL	MLT33-60RLFP	—	—
Lead of Actuator [mm/rotation]	0.5	0.25	Coarse: 0.5, Fine: 0.025	Coarse: 0.25, Fine: 0.005
Micrometer Readable Resolution [mm]	0.01	—	Coarse: 0.01, Fine: 0.0005	Coarse: 0.005, Fine: 0.0005
Weight [kg]	0.8	0.8	0.9	0.8



Outline Drawing

MLT33-60L Hexagonal socket head cap screw M4x8...4 screws

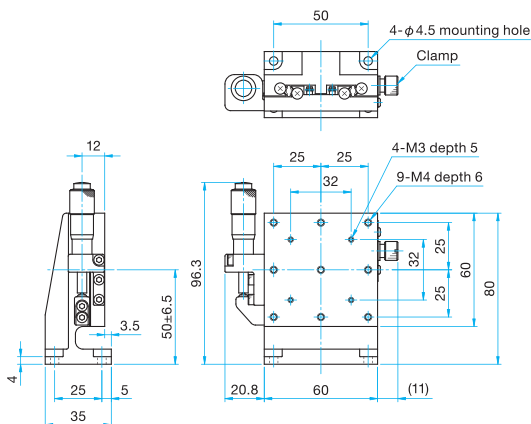

MLT33-60RL Hexagonal socket head cap screw M4x8...4 screws

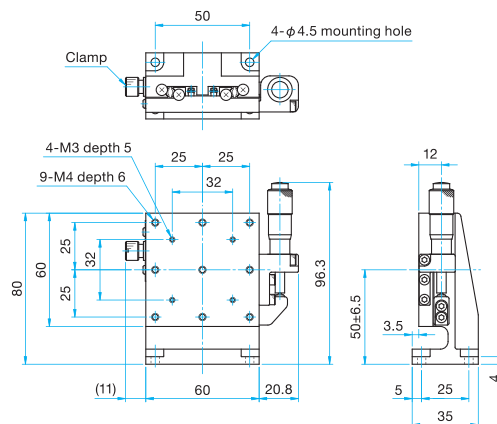

MLT33-60LFP Hexagonal socket head cap screw M4x8...4 screws 3mm

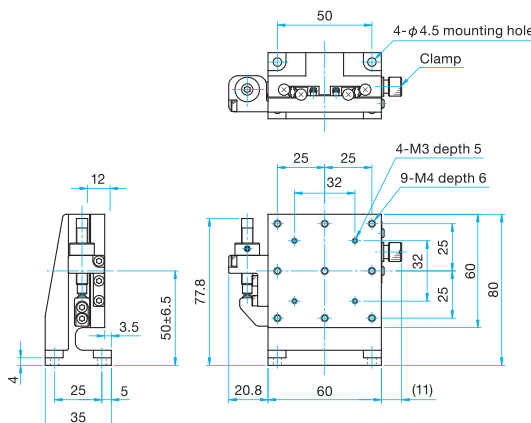

MLT33-60RLFP Hexagonal socket head cap screw M4x8...4 screws 3mm

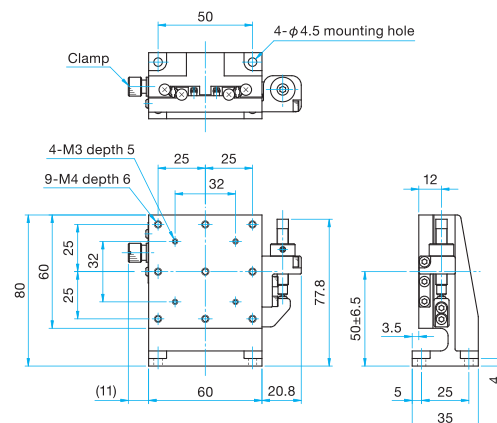

MLT33-60DML Hexagonal socket head cap screw M4x8...4 screws

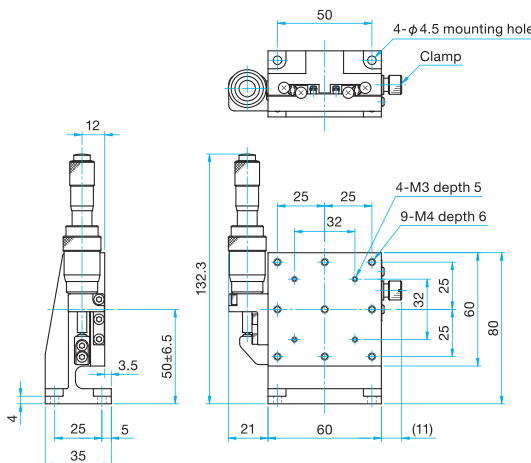

MLT33-60LWP Hexagonal socket head cap screw M4x8...4 screws

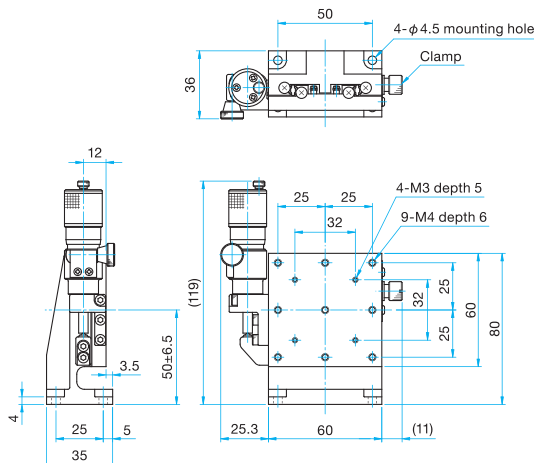

Application Systems

Machine Vision

Manual Positions

Motion Control Products

Optical & Mirror Holder

FA Parts

Measurement & Control

FA Electrical Parts

Tool & Measure

Cleanroom & AntiStatic

Index

X Axis

XY Axis

Z Axis

XZ Axis

XYZ Axis

Rotation

Goniometers /Tilt

Multiaxis

Linear Guide

□15mm

□25mm

□40mm

□50mm

□60mm

□70mm

□80mm

□100mm

□120mm

Others