

XY axis Leadscrew Slides XY axis Rack and Pinion Dovetail Stages

MLT1
MLT72W



Application Systems

Machine Vision

Manual Positions

Motion Control Products

Optical & Mirror Holder

FA Parts

Measurement & Control

FA Electrical Parts

Tool & Measure

Cleanroom & AntiStatic

Index

X Axis

XY Axis

Z Axis

XZ Axis

XYZ Axis

Rotation

Goniometers /Tilt

Multiaxis

Linear Guide

15mm

25mm

40mm

50mm

60mm

70mm

80mm

100mm

120mm

Others

The TAS is a leadscrew stage with dovetail slide guide and leadscrew adjustment system, suitable for fine adjustment.

The TARW/TAR are rack and pinion stages with dovetail slides, suitable for frequent operations that require quick motion and long travel.



Mounting Method

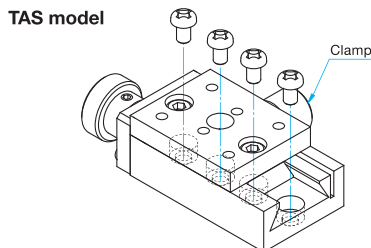

Stage must be translated to provide access to all of the mounting holes.

Guide

- ▶ Using the top plate spacer for TAR (SP-109) and that for TAS-2060 (SP-127-1), post holders and various stages can be mounted. Reference F050, F052

Attention

- ▶ Note that the TAS-152 has no clamping mechanism.
- ▶ Since the feed handle of TARW-25502 protrudes from the stage main body, it cannot be directly secured on a flat surface.
- ▶ There may be protrusions from the top surface depending on the components that secure the micrometer heads or the type of micrometer head. Note that some samples might not be able to be fixed on the stage depending on their shapes, or required travel might not be ensured.

Bottom Plate

Primary material: Aluminum
Finish: Black Anodized

TAR-34602/34802 include a base plate that allows mounting on instruments or bases fitted with M4 tapped holes on 50mm, preventing the handle from contacting the mounting surface.

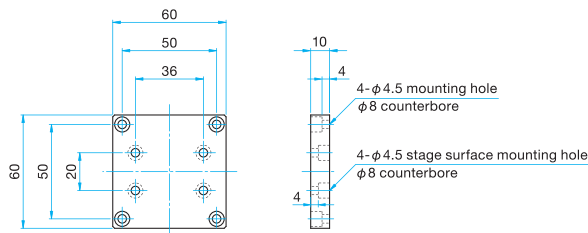

Specifications

Part Number	MLT12-15	MLT12-2430	MLT12-2060	MLT12-2550	MLT12-3460	MLT12-3480
Table Size [mm]	15×15	24×30	18×60	25×50	34×60	34×80
Travel [mm]	±3	±4	±7.5	±10	±15	±25
Positioning Slide	Dovetail method	Dovetail method	Dovetail method	Dovetail method	Dovetail method	Dovetail method
Primary Material	Brass	Brass	Brass	Brass	Brass	Brass
Finish	Super black chrome	Super black chrome	Super black chrome	Super black chrome	Super black chrome	Super black chrome
Load Capacity [N]	9.8 (1.0kgf)	68.7 (7.0kgf)	147 (15.0kgf)	78.5 (8.0kgf)	147 (15.0kgf)	196 (20.0kgf)
Travel Accuracy	Straightness [μm]					
	20	20	20	20	20	30
Max. Moment Capacity	Pitch [N·m]					
	0.05	0.5	0.5	0.6	1.5	1.5
	Roll [N·m]					
	0.05	0.5	0.5	0.6	1.5	1.5
Moment Stiffness	Yaw [N·m]					
	0.02	0.5	0.7	1	2	2.6
Parallelism [μm]	Pitch ["/N·cm]					
	—	1.5	1.27	3.67	1.2	1.1
	Roll ["/N·cm]					
	—	1.5	1.27	3.67	1.2	1.1
Parallelism [μm]	100	100	100	100	14	16
Weight [kg]	0.04	0.4	0.9	0.44	1	1.6

Catalog Code W7039

Catalog Code W7040



Outline Drawing

MLT12-15 Pan head screw M2x4...2 screws 2.5mm

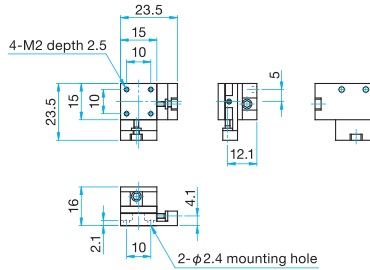

MLT12-2430 Pan head screw M3x5...4 screws

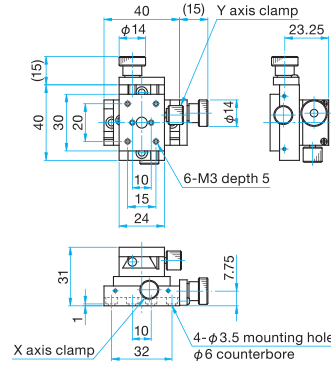

MLT12-2060 Hexagonal socket head cap screw M4x10...4 screws

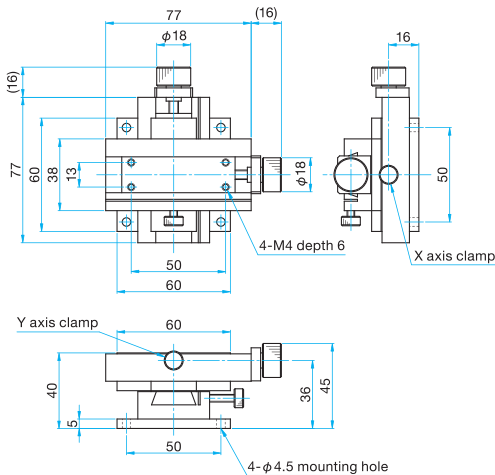

MLT12-2550 Pan head screw M3x8...4 screws

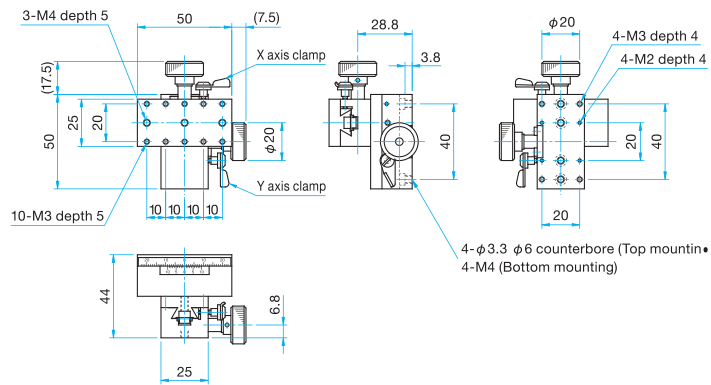

MLT12-3460 Hexagonal socket head cap screw M4x8...4 screws

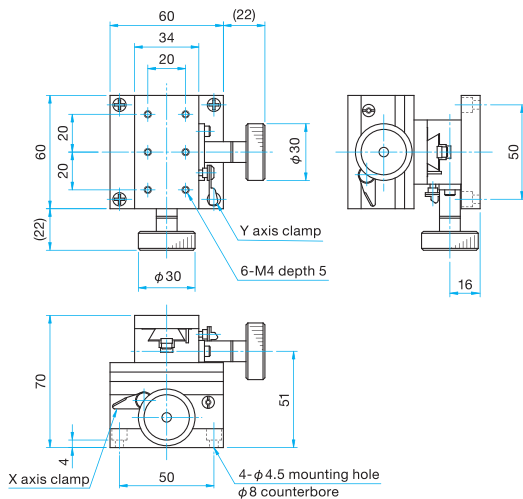

MLT12-3480 Hexagonal socket head cap screw M4x8...4 screws

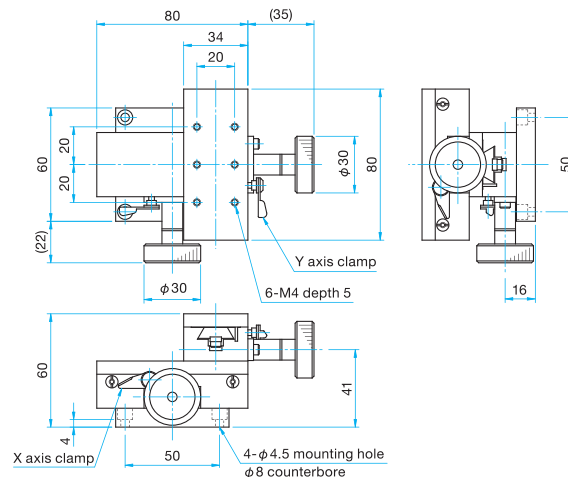

Application Systems

Machine Vision

Manual Positions

Motion Control Products

Optical & Mirror Holder

F A Parts

Measurement & Control

FA Electrical Parts

Tool & Measure

Cleanroom & AntiStatic

Index

X Axis

XY Axis

Z Axis

XZ Axis

XYZ Axis

Rotation

Goniometers /Tilt

Multiaxis

Linear Guide

□15mm

□25mm

□40mm

□50mm

□60mm

□70mm

□80mm

□100mm

□120mm