

XY axis Steel Extended Contact Slide Stages | MLT32-60C Stage size 60mm

RoHS

Application Systems

Machine Vision

Manual Positions

Motion Control Products

Optical & Mirror Holder

FA Parts

Measurement & Control

FA Electrical Parts

Tool & Measure

Cleanroom & AntiStatic

Index

X Axis

XY Axis

Z Axis

XZ Axis

XYZ Axis

Rotation

Goniometers /Tilt

Multiaxis

Linear Guide

15mm

25mm

40mm

50mm

60mm

70mm

80mm

100mm

120mm

Others

Hardened Steel linear stages with integrated bearing ways for superior stiffness, accuracy and durability.

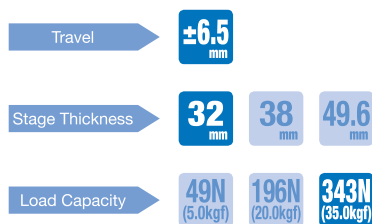

Guide

- ▶ Stainless steel types (MLT32-60C) are available for superior corrosion resistance. [Reference](#) G064
- ▶ The part number suffix FP indicates products with fine-pitch screws instead of standard micrometers.
- ▶ Fine Pitch screws have a screw pitch of 0.25mm and require a hex wrench or the optional hex wrench with knob (NSC) for adjustment. [Reference](#) H010



Attention

- ▶ Micrometer brackets may extend above the top surface of some stages. Check drawings for more information.

SPEC UP

Specifications

Table Size [mm]	60x60	
Travel [mm]	±6.5	
Positioning Slide	Extended contact ball guide	
Primary Material	Steel	
Finish	Super black chrome	
Load Capacity [N]	343 (35.0kgf)	
Travel Accuracy	Straightness [μm]	1
	Pitch ["]	25
	Yaw ["]	15
Max. Moment Capacity	Pitch [N·m]	13.2
	Roll [N·m]	13.2
	Yaw [N·m]	9.8
Moment Stiffness	Pitch ["/N·cm]	0.33
	Roll ["/N·cm]	0.33
	Yaw ["/N·cm]	0.32
Parallelism [μm]	50	
Running Parallelism [μm]	20	

Part Number	MLT32-60C	MLT32-60CFP	MLT32-60S	MLT32-60SFP	MLT32-60SDM	MLT32-60SWP
Opposite Model	—	—	MLT32-60SR	MLT32-60SRFP	—	—
Micrometer Position	Center	Center	Side	Side	Side	Side
Lead of Actuator [mm/rotation]	0.5	0.25	0.5	0.25	Coarse: 0.5 Fine: 0.025	Coarse: 0.25 Fine: 0.005
Micrometer Readable Resolution [mm]	0.01	—	0.01	—	Coarse: 0.01 Fine: 0.0005	Coarse: 0.005 Fine: 0.0005
Weight [kg]	0.9	0.9	0.9	0.9	1.0	0.9



Outline Drawing

MLT32-60C Hexagonal socket head cap screw M4x6...4 screws

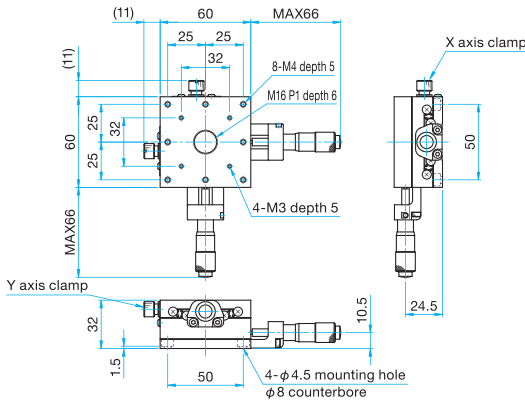

MLT32-60CFP Hexagonal socket head cap screw M4x6...4 screws 3mm

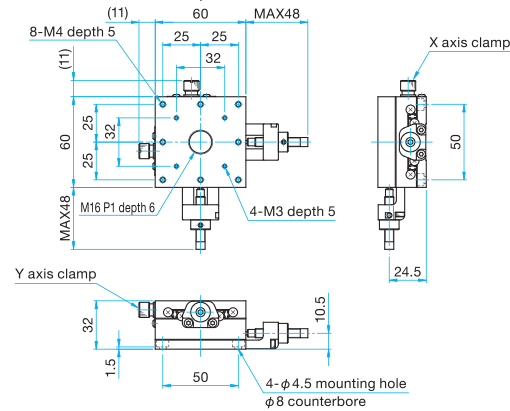

MLT32-60S Hexagonal socket head cap screw M4x6...4 screws

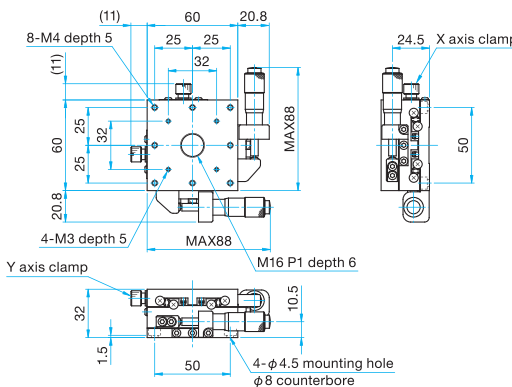

MLT32-60SR Hexagonal socket head cap screw M4x6...4 screws

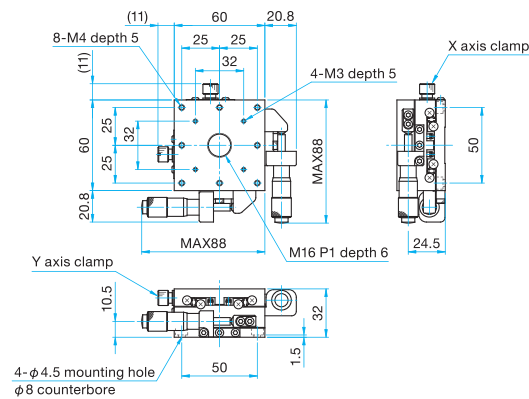

MLT32-60SFP Hexagonal socket head cap screw M4x6...4 screws 3mm

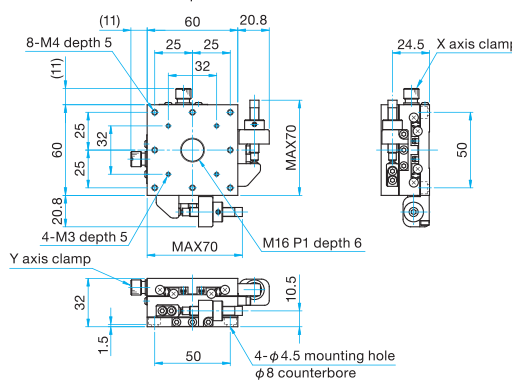

MLT32-60SRFP Hexagonal socket head cap screw M4x6...4 screws 3mm

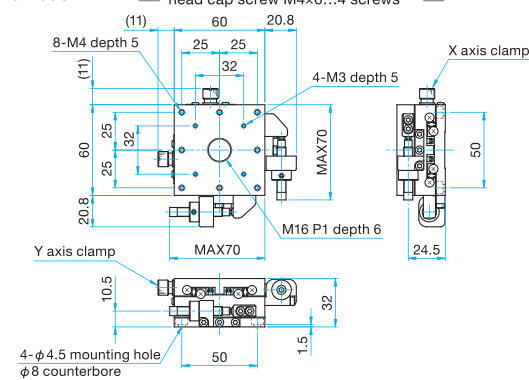

MLT32-60SDM Hexagonal socket head cap screw M4x6...4 screws

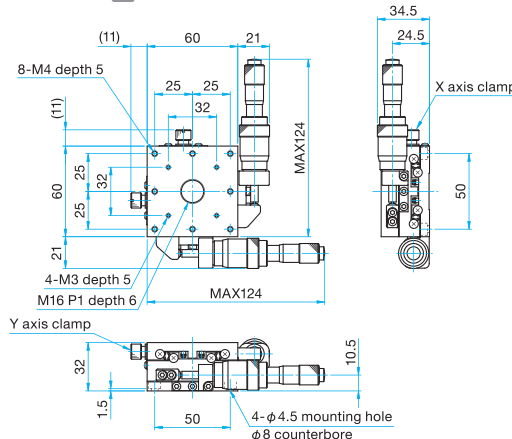

MLT32-60SWP Hexagonal socket head cap screw M4x6...4 screws

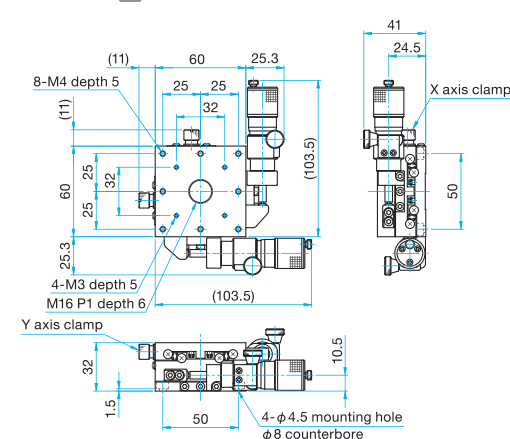

Application Systems

Machine Vision

Manual Positions

Motion Control Products

Optical & Mirror Holder

F A Parts

Measurement & Control

FA Electrical Parts

Tool & Measure

Cleanroom & AntiStatic

Index

X Axis

XY Axis

Z Axis

XZ Axis

XYZ Axis

Rotation

Goniometers /Tilt

Multiaxis

Linear Guide

□15mm

□25mm

□40mm

□50mm

□60mm

□70mm

□80mm

□100mm

□120mm

Others