

X axis Steel Extended Contact Slide Stages | MLT31-80 Stage size 80mm

RoHS

Application Systems

Machine Vision

Manual Positions

Motion Control Products

Optical & Mirror Holder

F A Parts

Measurement & Control

FA Electrical Parts

Tool & Measure

Cleanroom & AntiStatic

Index

X Axis

XY Axis

Z Axis

XZ Axis

XYZ Axis

Rotation

Goniometers /Tilt

Multiaxis

Linear Guide

15mm

25mm

40mm

50mm

60mm

70mm

80mm

100mm

120mm

Others

Hardened Steel linear stages with integrated bearing ways for superior stiffness, accuracy and durability.

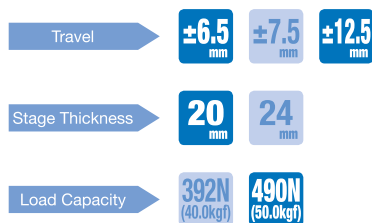

Guide

- ▶ The part number suffix FP indicates products with fine-pitch screws instead of standard micrometers.
- ▶ Fine Pitch screws have a screw pitch of 0.25mm and require a hex wrench or the optional hex wrench with knob (NSC) for adjustment.



Reference H010

Attention

- ▶ Micrometer brackets may extend above the top surface of some stages. Check drawings for more information.

SPEC UP

Specifications		
Table Size [mm]		80×80
Travel [mm]		±12.5 (±6.5 for SDM and SWP)
Positioning Slide		Extended contact ball guide
Primary Material		Steel
Finish		Super black chrome
Load Capacity [N]		490 (50.0kgf)
Travel Accuracy	Straightness [μm]	1
	Pitch ["]	25
	Yaw ["]	15
Max. Moment Capacity	Pitch [N·m]	19.45
	Roll [N·m]	21.55
	Yaw [N·m]	17.7
Moment Stiffness	Pitch ["/N·cm]	0.1
	Roll ["/N·cm]	0.06
	Yaw ["/N·cm]	0.1
Parallelism [μm]		30
Running Parallelism [μm]		10

Part Number	MLT31-80C	MLT31-80CFP	MLT31-80S	MLT31-80SFP	MLT31-80SDM	MLT31-80SWP
Opposite Model	—	—	MLT31-80SR	MLT31-80SRFP	—	—
Micrometer Position	Center	Center	Side	Side	Side	Side
Lead of Actuator [mm/rotation]	0.5	0.25	0.5	0.25	Coarse: 0.5 Fine: 0.025	Coarse: 0.25 Fine: 0.005
Micrometer Readable Resolution [mm]	0.01	—	0.01	—	Coarse: 0.01 Fine: 0.0005	Coarse: 0.005 Fine: 0.0005
Weight [kg]	0.9	0.9	0.9	0.9	0.9	0.9

Catalog Code **W7006**



Outline Drawing

MLT31-80C Hexagonal socket head cap screw M4x8...4 screws

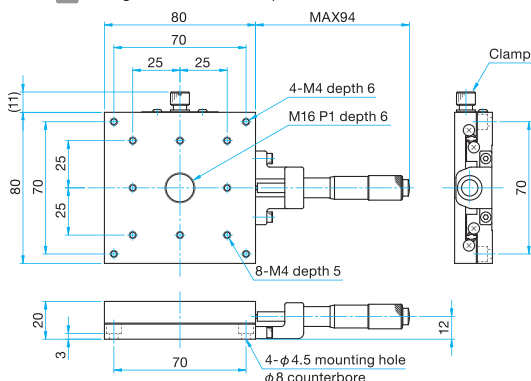

MLT31-80CFP Hexagonal socket head cap screw M4x8...4 screws 3mm

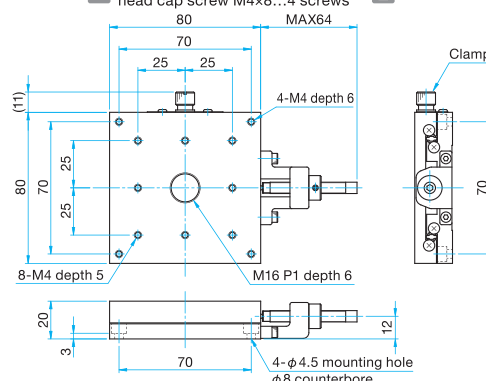

MLT31-80S Hexagonal socket head cap screw M4x8...4 screws

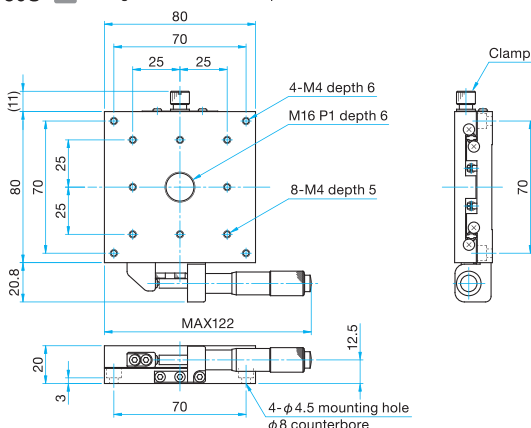

MLT31-80SR Hexagonal socket head cap screw M4x8...4 screws

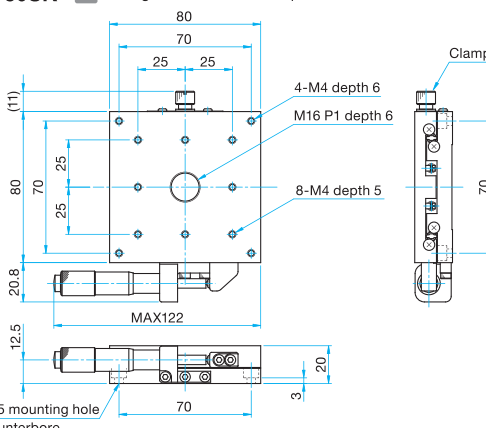

MLT31-80SFP Hexagonal socket head cap screw M4x8...4 screws 3mm

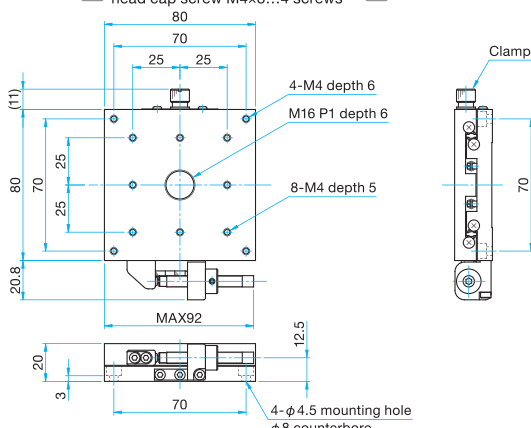

MLT31-80SRFP Hexagonal socket head cap screw M4x8...4 screws 3mm

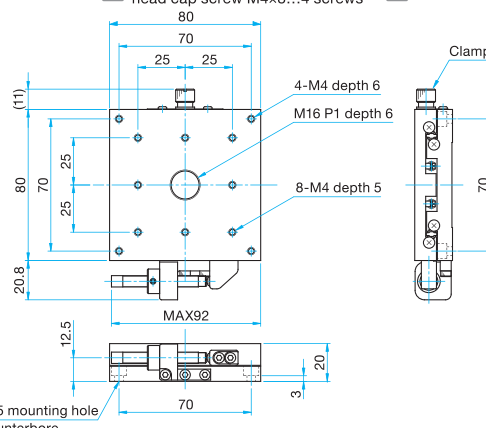

MLT31-80SDM Hexagonal socket head cap screw M4x8...4 screws

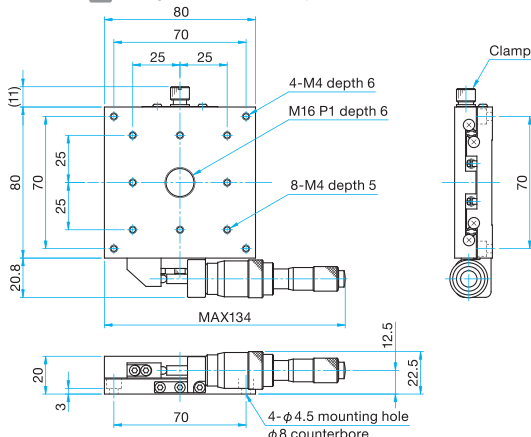

MLT31-80SWP Hexagonal socket head cap screw M4x8...4 screws

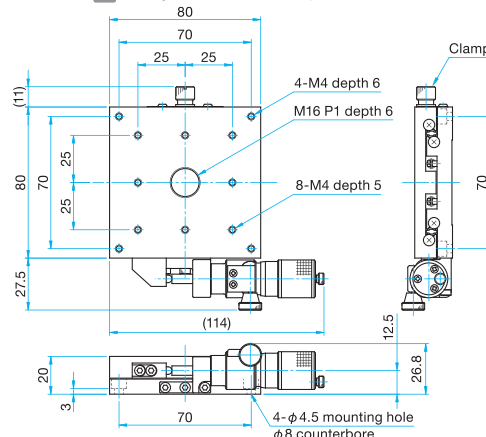

Application Systems

Machine Vision

Manual Positions

Motion Control Products

Optical & Mirror Holder

F A Parts

Measurement & Control

FA Electrical Parts

Tool & Measure

Cleanroom & AntiStatic

Index

X Axis

XY Axis

Z Axis

XZ Axis

XYZ Axis

Rotation

Goniometers /Tilt

Multiaxis

Linear Guide

15mm

25mm

40mm

50mm

60mm

70mm

80mm

100mm

120mm

Others