

Rotating Fiber Holder (with adsorption function)

FHRMW

RoHS

This rotary fiber holder is used to rotate and adjust the polarization plane of polarization maintaining fiber. It is attached to the holder mounting section of the alignment unit.



- A magnetizing bolt is built into the plastic holder, and the magnetic force of the fiber holder's magnet gently clamps the polarization-maintaining fiber.
- Fiber retention part is removable by magnet.
- This product comes with a 2-meter vacuum suction tube.
- Can be attached to the DAU-8100A series alignment unit.

Guide

- ▶ We have two types of fiber holders: the FHRAW series with a suction function at the tip and the FHRA series without a suction function.
- We also have three jacket diameters of 250 μm , 400 μm , and 900 μm . All cladding diameters are specified at 125 μm .
- ▶ Rotating fiber holders (FHRM series) are also available.



Attention

- ▶ When removing the fiber retention unit, please do so at the 0 degree position.

Motorized 12-axis Optical Fiber Alignment Stage Unit (DAU-8100A)-0
Composition : DAU-8100A-L+DAU-8100A-R

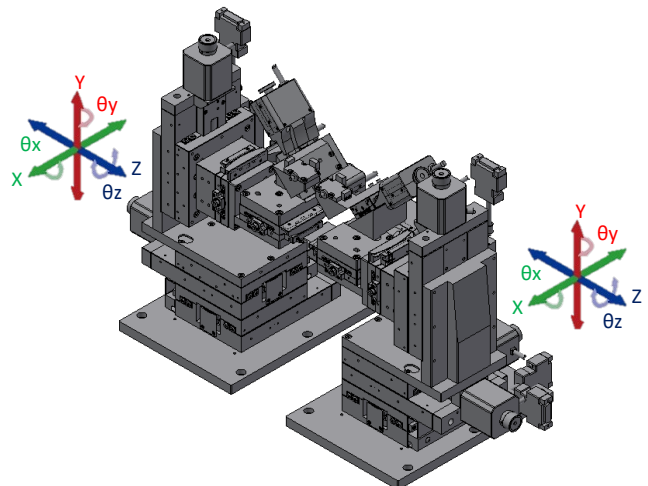

FHRMW-E2306

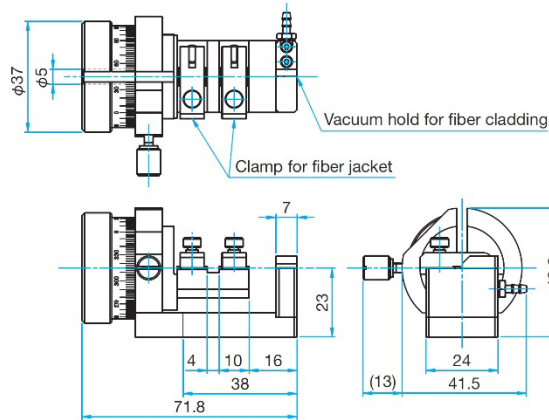
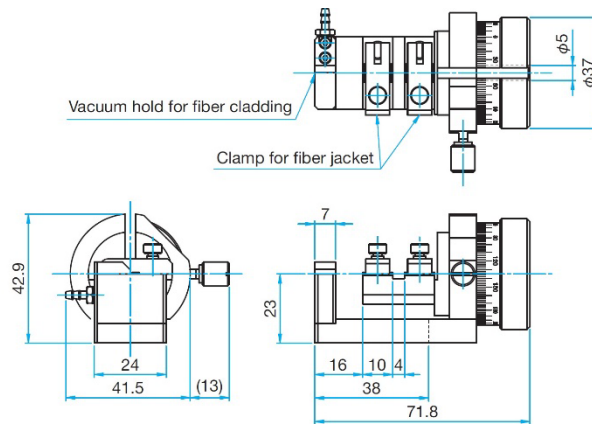
FHRMW-125/*L****FHRMW-125/***R****Rotating Fiber Holder**

Specifications	FHRMW-125/250L	FHRMW-125/400L	FHRMW-125/900L
Part Number	FHRMW-125/250L	FHRMW-125/400L	FHRMW-125/900L
(Opposite Model)	FHRMW-125/250R	FHRMW-125/400R	FHRMW-125/900R
Adjustment Range [°]	360		
Fiber optic cladding diameter [μm]	125		
Fiber optic jacket diameter [μm]	250	400	900
Material	Aluminum		
Finish	Black anodized		
Weight [kg]	0.12		

Air fitting	
Part number (Air fitting)	LC-0425-M3(Nihon Pisco Co., Ltd.) Applicable tube inner diameter: φ2.5